

BOS-12

Sferik blok yatak

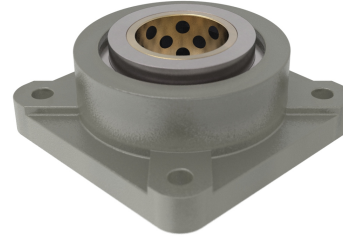
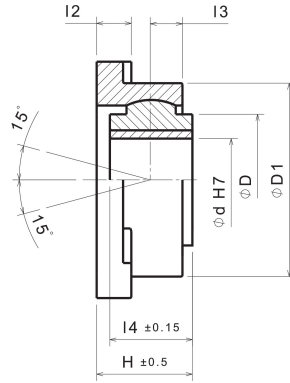
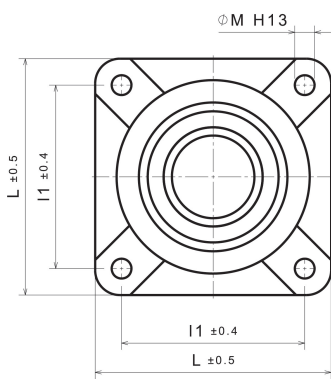

Tanımlama:

Sferik blok yatak

Özellikler:

Temel Malzeme	Özel Mangan Bronz (SO#50SP2)
Kendinden Yağlamalı	Evet
Yağlayıcı	Grafit
Yük P	100 N/mm ²
Kayma Hızı	30 m/min
P*V Değeri	200 N/mm ² x m/min
Çalışma Isısı	-50°C / +200°C (max. 300°C)
Sürtünme Katsayısı	0,07

Varyantlar:

Ürün numarası	Ürün Adı	İç Ø d	Dış Ø D	Uzunluk L	Yükseklik H	D1	I1	I2	I3	I4	M (DIN EN 20273)	Max. Yük (Dış Kovan) (kN)
63512010	BOS-12-10	10	33,3	76	23	54	57	8	6	15	4xM8	3,86
63512012	BOS-12-12	12	33,3	76	23	54	57	8	6	15	4xM8	3,86
63512015	BOS-12-15	15	33,3	76	23	54	57	8	6	15	4xM8	3,86
63512020	BOS-12-20	20	39,7	89	27	64	64	10	10	20	4xM10	5,9
63512025	BOS-12-25	25	39,7	89	30	64	64	10	10	25	4xM10	5,9
63512030	BOS-12-30	30	51	110	36	79	79	11	13	30	4xM12	8,18
63512035	BOS-12-35	35	60,3	121	43	95	92	14	16	35	4xM12	11
63512040	BOS-12-40	40	60,3	121	45	95	92	14	16	40	4xM12	11
63512045	BOS-12-45	45	73	133	51	108	102	16	16	45	4xM12	12
63512050	BOS-12-50	50	79,3	143	58	117	111	16	21	50	4xM12	14,5
63512055	BOS-12-55	55	83	165	62	137	130	17	22	55	4xM16	16
63512060	BOS-12-60	60	83	165	65	137	130	17	22	60	4xM16	16
63512080	BOS-12-80	80	108	197	81	171	152	22	29	80	4xM20	27
63512090	BOS-12-90	90	130	241	91	210	197	25	32	80	4xM20	30,5
63512100	BOS-12-100	100	130	241	91	210	197	25	32	80	4xM20	30,5